

OWNERS MANUAL

# Renaissance Cooking Systems

For Outdoor Use Only

Installation, Operation, Maintenance  
Instructions  
And Parts List

Models: RON27, RON30,  
RON36 and RON42

<b>Contents</b>	<b>Page</b>
For Your Safety	3
Safety Rules	4
Gas Connection	5
Gas Barbecue Specifications	6
LP Tank Requirement	8
Installation Location	9
Clearances	9
Electrical	11
Burner Adjustments	12
Lighting Instructions	14
Operation	15
Cleaning and Maintenance	15
Parts Removal and Replacement	17
Trouble Shooting	18
Exploded View	19
Parts Identification	20

### **Message to the Proud Owner**

Congratulations on the purchase of the high quality, high performance grill.

Read this manual carefully to understand all the instructions about how to install, operate and maintain for optimum performance and longevity.

Keep this manual in a safe place for future reference.

For any assistance, contact us. Make sure to provide the Model Number and Serial Number of the grill.

Thank you for buying our grill. We wish you years of cooking pleasure.

## **For Your Safety**

1. If you smell gas:
2. Shut off gas to the appliance.
3. Extinguish any open flames.
4. Open lid.
5. If odor continues, immediately call your gas supplier.

### **WARNING**

Read the “Lighting Instructions” in this manual, before lighting this appliance.

## **For Your Safety**

1. Do Not store or use gasoline or other flammable vapors and liquids in the vicinity of this or any other appliance.
2. An LP cylinder not connected for use shall not be stored in the vicinity of this or any other appliance.

**TESTED IN ACCORDANCE WITH ANSI  
STANDARD FOR OUTDOOR COOKING GAS  
APPLIANCES. THIS GRILL IS FOR  
OUTDOOR USE ONLY.**

Check your local building codes for the proper method of installation. In the absence of local codes, this unit should be installed in accordance with the National Fuel Gas Code No. Z223.1-CAN/CGA—B149.1, natural gas installation code or CAN/CGA—B149.2, propane installation code.

**CALIFORNIA PROPOSITION 65-**

**WARNING**

The Burning of gas cooking fuel generates some by-products which are on the list of substances which are known by the State of California to cause cancer or reproductive harm. California law requires businesses to warn customers of potential exposure to such substances. To minimize exposure to these substances, always operate this unit according to the use and care manual, ensuring you provide good ventilation when cooking with gas.

## Safety Rules

1. It is important to follow these rules to avoid fire hazard, property damage or bodily injury from improper installation or usage of the grill. For safety, READ all rules carefully and check local codes.
2. It is prohibited to install the grill in recreational vehicles/mobile homes, trailers, boats, etc. The grill is for outdoor installation and use only.
3. Ensure proper installation by following the installation instructions. Make sure to know where the gas supply shut-off valve is located. It should be readily and easily accessible.
4. Check all gas line joints or connection for gas leak with soap water solution. **Never check gas leak with an open flame.**
5. Do not attempt to repair or replace any part of the grill unless specifically recommended in this manual. All other services should be performed by a qualified service technician.
6. Do not place clothing or other flammable material on or near the appliance. Do not wear loose-fitting clothes or long sleeves while using the grill as some fabrics can be highly flammable.
7. Children should be carefully supervised when they are in the vicinity of the grill. Do not allow them to get close while in use. Items of interest to children should not be stored in or around the grill in the cabinet or in the masonry enclosure. Portions of the grill can be extremely hot while in use and can cause severe burns.
8. Protect your hand with a glove or mitt when opening and operating the grill. Open grill lid slowly to allow heat and smoke to escape before fully opening.
9. Never use aluminum foil to line the crumb pan or grill racks. This can alter airflow for proper combustion and also build up heat in the control area causing the knobs and igniters to melt.
10. Grease is highly flammable. Allow hot grease to cool down before attempting to handle it. Clean grease tray often so that grease does not accumulate and stay in it.
11. Do not use the grill in a windy area.
12. Do not obstruct the flow of air into the front of the grill.

## Gas Connections

Check gas type – Proper sized orifices must be used.

**Do Not** connect an unregulated gas line to the appliance.

Safe and satisfactory operation depends to a great extent on the proper installation of the appliance. The installation must comply with the local codes, or in the absence of local codes, with either the National Fuel Gas Code, ANSI Z223.1 or CAN/CGA – B149.1 or 149.2.

Installer supplied manual gas shut-off valve must be installed in an easily accessible location in the gas supply line ahead of the pressure regulator (4"W.C.) which is also to be provided by the installer.

The outdoor cooking gas appliance and its individual shut-off valve must be disconnected from the gas supply piping system during any pressure testing of the system at test pressures in excess of  $\frac{1}{2}$  Psi (3.5kPa).

The outdoor cooking gas appliance must be isolated from the gas supply piping system by closing its individual manual shut-off valve during any pressure testing of the gas supply piping system at test pressures equal to or less than  $\frac{1}{2}$  Psi (3.5kPa).

The supply line must be sized and installed to provide a sufficient supply of gas to meet the maximum demand of the grill without undue loss of pressure. The sealant used on the threaded joints of the gas pipe must be a type resistant to the action of LP gases.

## GAS BARBECUE SPECIFICATIONS

### **BURNER INPUT RATING:**

Grill	15,000 BTU / each
Rotisserie	12,500 BTU / each
Side Burner	12,000 BTU / each
Light Wattage	12V

### **Natural Gas Connection: (Installer To Provide Regulator)**

<b>Appliance pressure</b>	<b>4" W.C.</b>
<b>Inlet pressure</b>	<b>5" – 14" W.C.</b>

Check with your local gas utility company or with local codes before installing gas lines.

Assembly pipe fittings as shown. Apply pipe compound on male joints only. Install regulator with the proper orientation for the gas flow.

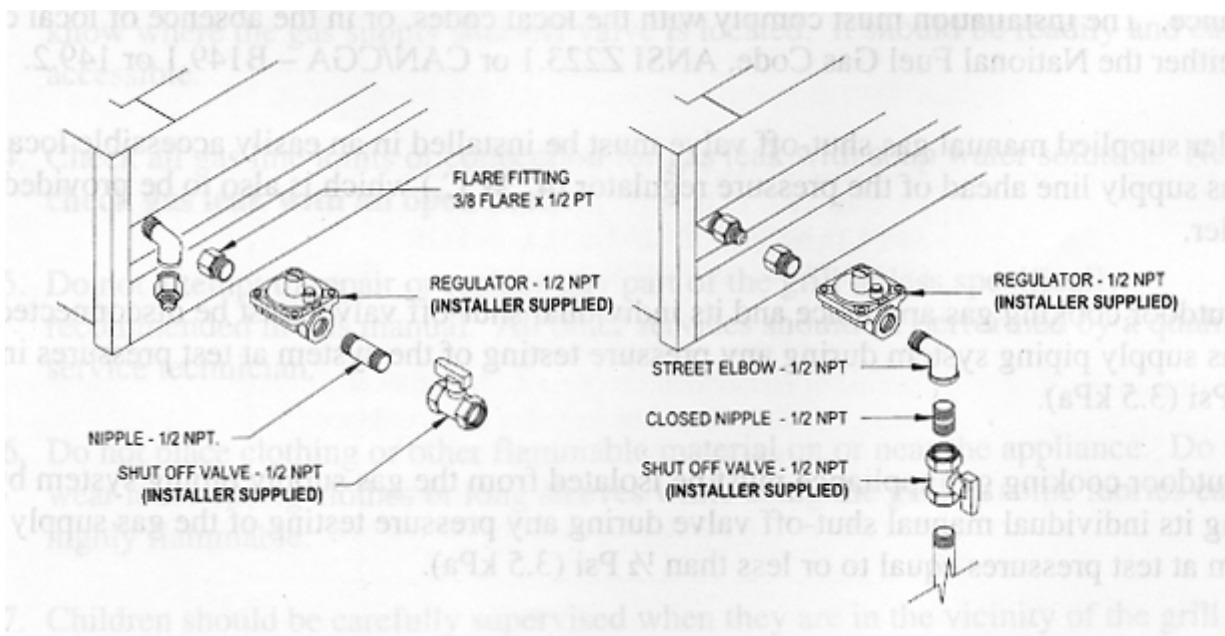

## LP Gas Connection

<b>Appliance pressure</b>	<b>10" W.C.</b>
<b>Inlet pressure</b>	<b>11" – 14" W.C.</b>

Purchase a standard 20 lbs. LP tank with QCC – 1 fitting.

Assemble pipe/hose assembly as shown.

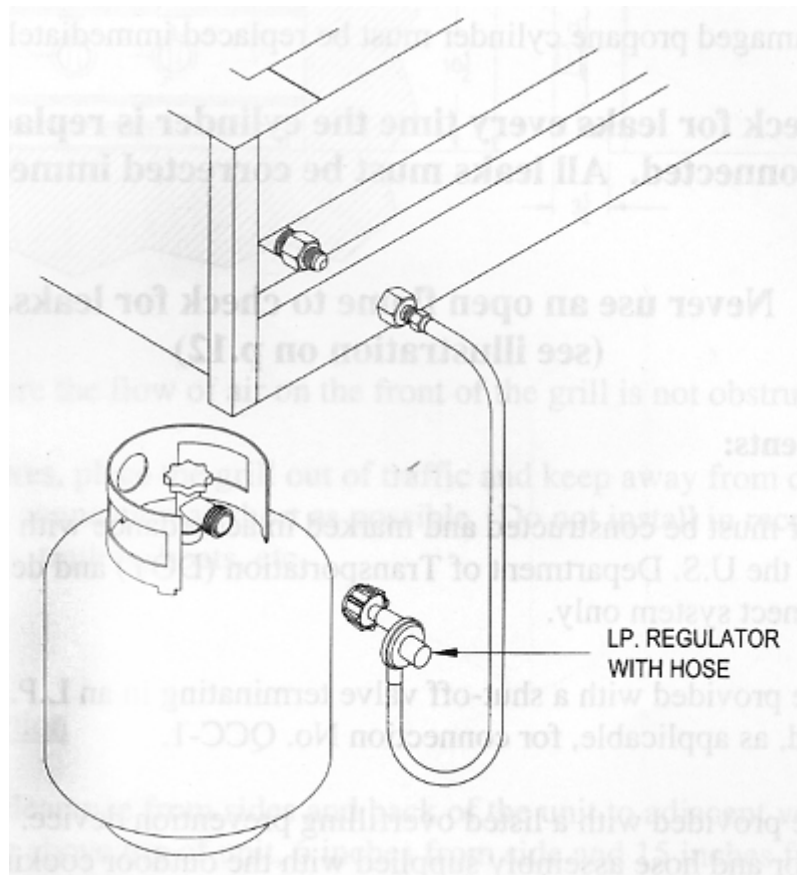

After completion of assembly, turn the tank valve on and turn the control valves on the grill to the 'HI/ING' position for 10 – 15 seconds to purge the line of air.

Inspect the hose before each use of the appliance. If it is evident there is excessive abrasion or wear, or the hose is cut, it must be replaced prior to the appliance being put into operation. The replacement hose assembly shall be that specified by the manufacturer.

To connect, insert the regulator inlet into the tank valve and turn the black coupler clockwise until the coupler tightens up. **DO NOT OVER TIGHTEN THE COUPLER.**

To disconnect, turn the tank valve off. Hold the coupler sleeve and turn counter clockwise. The inlet line will be disengaged.

If the appliance is not in use, the gas must be turned off at the supply cylinder. Cylinder must be stored outdoors out of reach of children and must not be stored in a building, garage or any other enclosed area.

A dented, rusty or damaged propane cylinder must be replaced immediately.

**Check for leaks every time the cylinder is replaced or reconnected. All leaks must be corrected immediately.**

**Never use an open flame to check for leaks.  
(see illustration on p.12)**

### **LP Tank Requirements:**

The L.P. gas cylinder must be constructed and marked in accordance with the specifications for L.P. gas cylinders of the U.S. Department of Transportation (DOT) and designed for use with a QCC-1 quick disconnect system only.

The cylinder must be provided with a shut-off valve terminating in an L.P. gas supply cylinder valve outlet specified, as applicable, for connection No. QCC-1.

The cylinder must be provided with a listed overfilling prevention device. The pressure regulator and hose assembly supplied with the outdoor cooking gas appliance must be used. Replacement of pressure regulators and hose assemblies can be purchased from authorized dealers.

The cylinder supply system must be arranged for vapor withdrawal. Make sure the LP cylinder has a collar to protect the cylinder valve.

- (a) Do not store a spare LP gas cylinder under or near this appliance.
- (b) Never fill the cylinder beyond 80 percent full.
- (c) If the information in (a) and (b) are not strictly followed, a death-causing fire or serious injury may occur.

## Installation Location For All Models

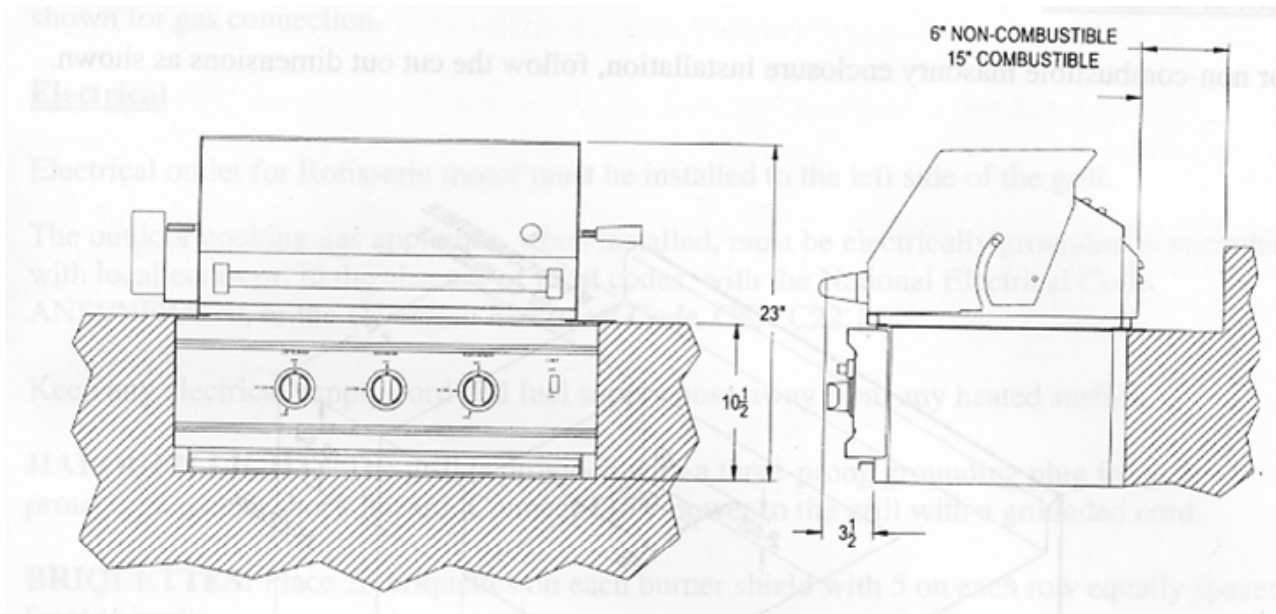

Choose a location where the flow of air on the front of the grill is not obstructed.

Due to high temperatures, place the grill out of traffic and keep away from clothing, furniture, etc. Keep the gas line connection as short as possible. Do not install in recreational vehicles/mobile homes, trailers, boats, etc.

### **Clearances**

#### Combustible Construction

Minimum horizontal clearance from sides and back of the unit to adjacent vertical combustible construction extending above top of unit, 6 inches from side and 15 inches from back. Do not locate under overhead unprotected combustible construction.

#### Non-Combustible Construction

Sides of the grill can be 0" from non-combustible wall, below the cooking surface.

#### Built-in Installation

For non-combustible masonry enclosure installation, follow the cut out dimensions as shown.

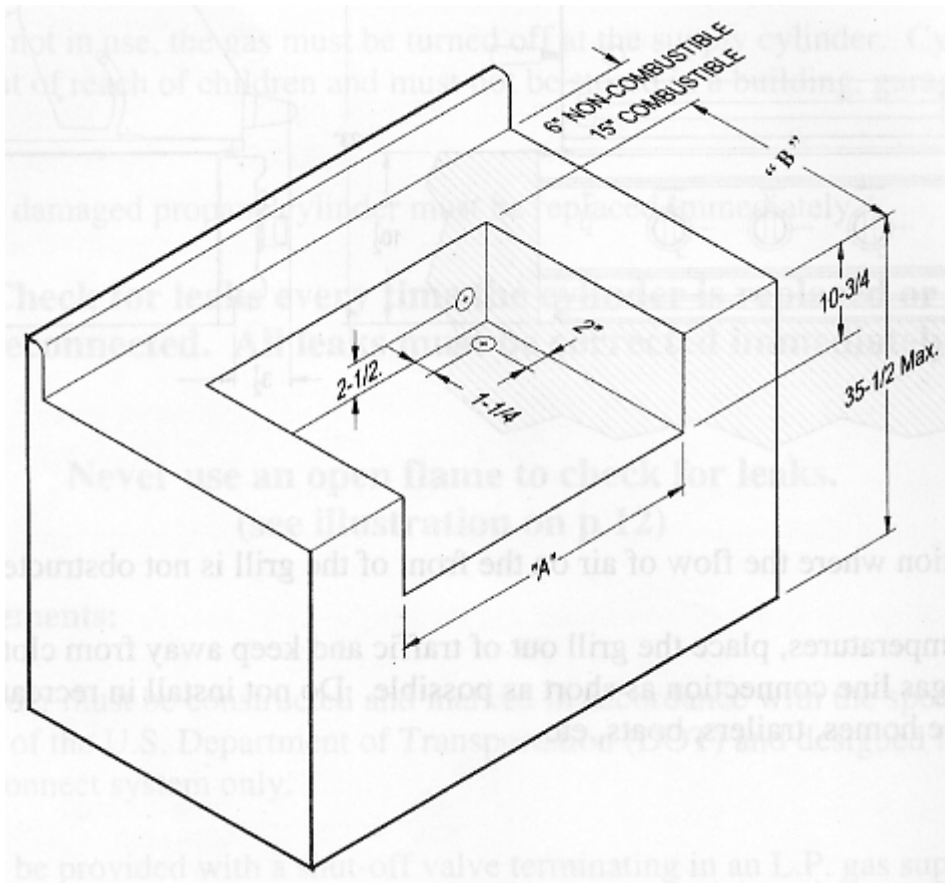

Model Size	"A" Dim	"B" Dim
27"	29 1/4"	17 3/8"
30"	32 7/8"	19 5/8"
36"	38 1/2"	18"
42"	45"	20"

The bottom of the grill must be supported on both sides and back or full width with opening as shown for gas connection.

### **Electrical**

Electrical outlet for Rotisserie motor must be installed to the left side of the grill.

The outdoor cooking gas appliance, when installed, must be electrically grounded in

accordance with local codes or, in the absence of local codes, with the National Electrical Code, ANSI/NFPA 70, or the *Canadian Electrical Code*, CSA C22.1.

Keep any electrical supply cord and fuel supply hose away from any heated surface.

**HALOGEN LIGHT:** The grill is provided with a three-prong grounding plug for your protection against shock hazard. Connect 115V power to the grill with a grounded cord.

**BRIQUETTES:** (If Supplied) Place the briquettes on each burner shield with same quantity on each row equally spaced. Do not cover up the holes in the flavorizer plate with the briquettes.

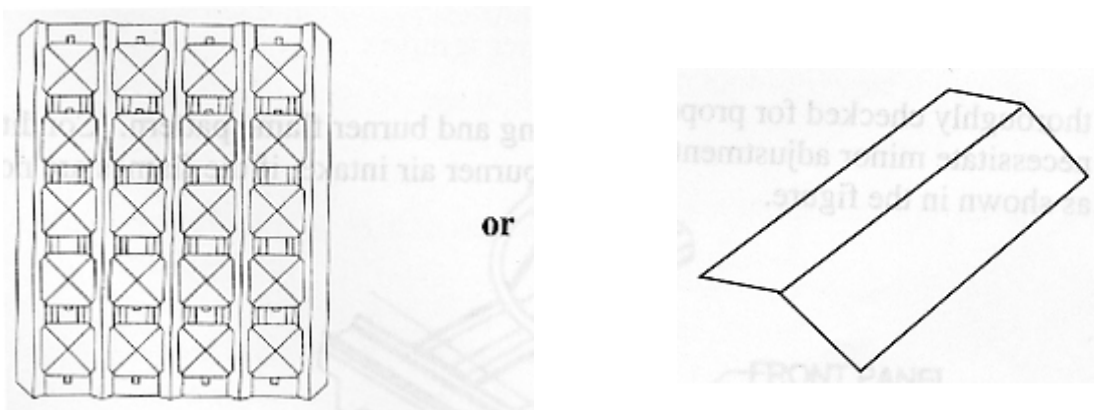

**Radiant burner covers (on the right) may be utilized in this model**

### Leak Testing

All gas piping and connections must be tested for leaks after installation or service. All leaks must be corrected immediately.

Open the valve (shut-off or 'ON' LP tank). Test for leaks by applying liquid soap solution to all joints. Bubbles forming indicate gas leak.

NEVER USE AN OPEN FLAME TO CHECK FOR LEAKS.

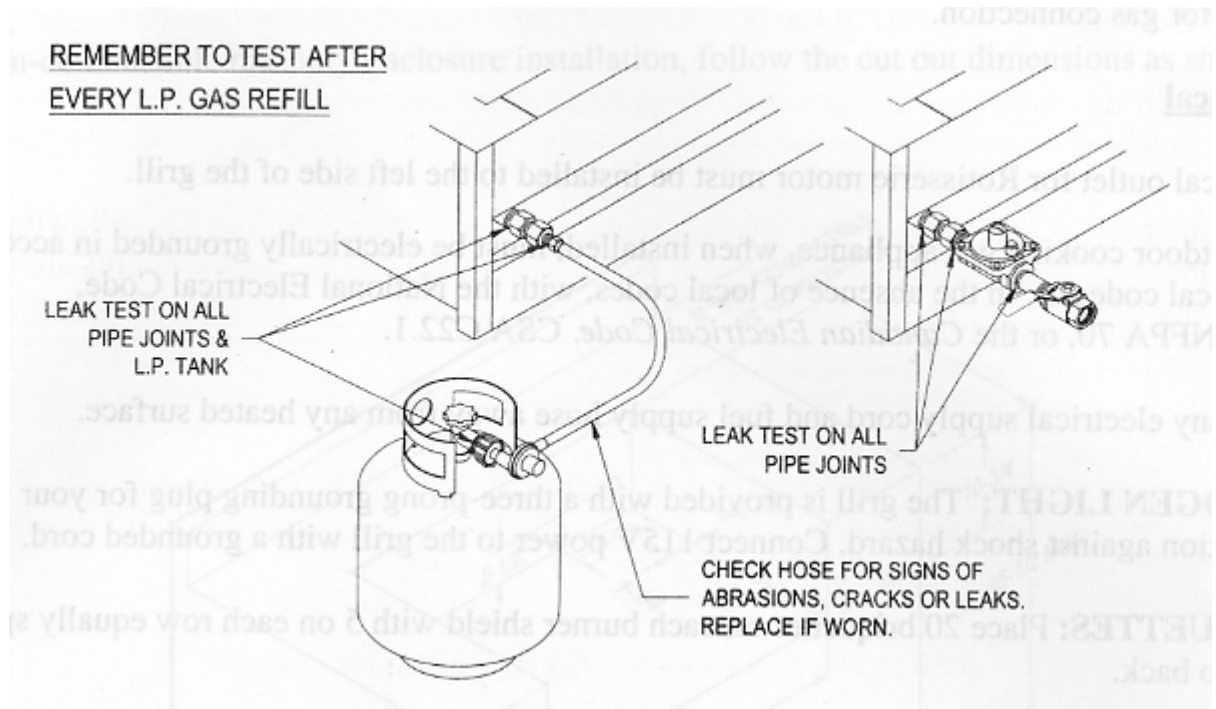

### Burner Adjustments

Every grill is thoroughly checked for proper lighting and burner flame pattern. Conditions at the location may necessitate minor adjustment of the burner air intake, if the flames are not steady/stable as shown in the figure.

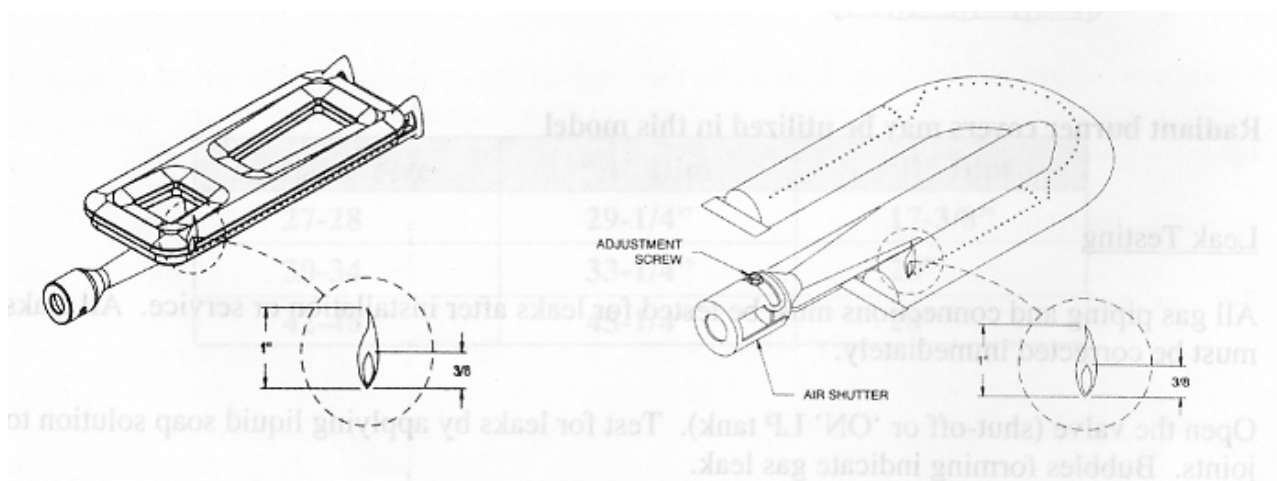

The flame should be full length of the burner, blue and stable. The air intake should be adjusted ONLY if the flame is lifting off of the ports or has yellow tipping.

If flame is lifting, turn the air shutter clockwise reducing this intake. The screw should be loosened before turning the air shutter.

If the flame has yellow tipping, the air shutter should be turned counter clockwise allowing more air in. This will stabilize the flame. Make sure to tighten the screw after adjustments are made. Remove the front panel as shown (Page 17) in the diagram to access the burner front (air shutter).

In order to provide gas to the burner, the orifice must be inside the burner venture opening. Check to ensure that the burner is properly secured at the front and back.

## **Lighting Instructions**

### ***Before Lighting:***

Check gas line/hose for signs of wear, abrasion or cuts. If evidence of deterioration is visible, replace the part prior to use.

If you smell gas, check for leaks. If odor continues, immediately call for service.

Keep your face and body away from the grill top when lighting.

### **Grill and Rotisserie Burner Lighting**

1. Open lid before lighting. Make sure all burners are in the 'OFF' position.
2. Push and turn burner knob to 'HI/IGN' position.
3. Turn slowly allow gas to fill burner.
4. Continue step 3 until you have burner ignition.

### **Operation**

**DO NOT LEAVE YOUR GRILL UNATTENDED WHILE IN OPERATION.**

Grill: Grill burners are controlled individually with a control knob. After lighting, turn the knob to HI, LO or in between as desired. Turn on as many burners as required.

The top cover may be closed during grilling. Keep the top cover in closed position during the pre heat period.

Rotisserie: Turn the control knobs to HI.  
Plug in the motor power cord to a properly grounded receptacle.

Rotisserie cooking can be done with grill burners as well as with the Rotisserie burner 'ON'.

The skewer slides in from the side with the tip sliding into the motor shaft adapter. The slot on the handle side should be on the side support panel edge.

Use the prongs to hold the meat. Tighten thumbscrew on the prong hubs to secure in place.

When ready, turn the switch on the motor box to the 'NO' position. The skewer will rotate slowly.

Stop the motor before removing the skewer.

## **Cleaning and Maintenance**

Cleaning: Your Bar-B-Q grill works better and lasts longer if properly cleaned and maintained. Clean the grill immediately after every use. Turn grill off before starting to clean. Protect your hand with a good mitt when cleaning the hot grill. Use a wire brush, dip in water and scrub the grill to soften and loosen food spills. The food spills will fall into the crumb pan.

Do not use Aerosol cleaners on hot grill surface. Chemicals may produce noxious fumes and may ignite on contact with the hot surface.

Shield: Burner shields (Briquette holder) are made up of stainless steel. After every use, allow the shields to cool down. Remove and soak in water with a mild soap or detergent. Replace when dry along with the briquettes.

### Crumb Tray / Grease Pan:

Empty grease pan as required to prevent overflowing. After use, remove the full width crumb pan and brush off the contents. Clean with hot water and soap or detergent.

All stainless steel parts should be cleaned with a mild soap or detergent or with a liquid

cleanser especially made for stainless steel. Never attempt to clean stainless steel with steel wool, abrasive clothes or powders.

### Maintenance

Keep outdoor cooking gas appliance area clear and free from combustible materials, gasoline and other flammable vapors and liquids.

Do not obstruct the flow of combustion and air ventilation.

Keep the ventilation opening(s) of the cylinder enclosure free and clear from debris.

Visually check burner flames.

There are many different stainless steel cleaners available. Always use the mildest cleaning procedure first, scrubbing in the direction of the grain. To touch up noticeable scratches in the stainless steel, sand very lightly with dry 100 grit emery paper in the direction of the grain.

Specks of grease can gather on the surfaces of the stainless steel and bake on to the surface and give the appearance of rust. For removal use, an abrasive pad (Scotch Brite is good) in conjunction with a stainless steel cleaner. Always rub in the direction of the grain. Never scrub the stainless steel with steel wool. Steel particles left on the stainless steel will soon rust and give the appearance that the parts are rusting.

The burners, control area, crumb pan, etc. should be kept clean at all times. During prolonged non-use of the grill, spiders and insects can nest in areas that will adversely affect the functioning of the grill. Check burner inlets, orifice hood (gas inlet to burner), igniter, sparkers, etc. thoroughly and clean before use.

## Front Panel Removal For All Models

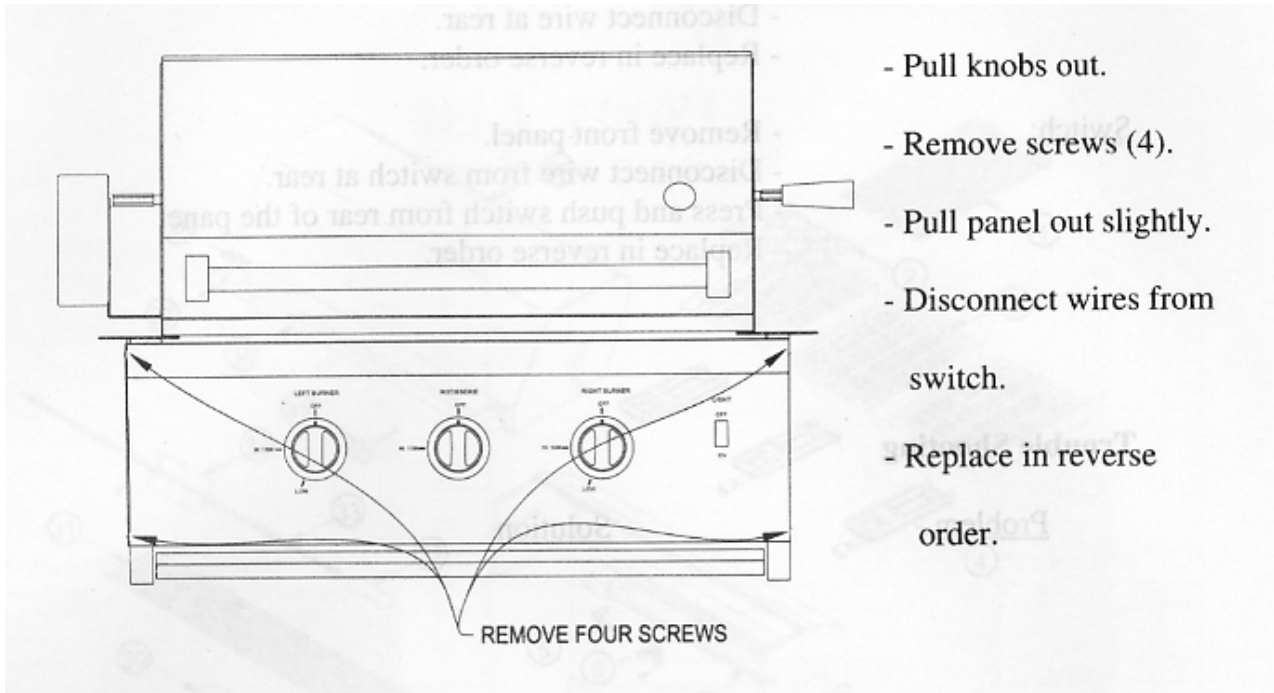

- Pull knobs out.
- Remove screws (4).
- Pull panel out slightly.
- Disconnect wires from switch.
- Replace in reverse order.

## Parts Removal and Replacement

### Grill Burner:

- Remove top grates.
- Remove briquettes and shields
- Unscrew the burner at rear and slide out.
- Clean and replace in reverse order.

### Grill Sparker:

- Remove top grates, briquettes and shields.
- Unscrew the sparker bracket from inside.
- Disconnect wire.
- Replace in the reverse order.

### Rotisserie Sparker:

- Remove sparker cover – lift and pull.
- Remove sparker screws and pull out.
- Disconnect wire at rear.
- Replace in reverse order.

### Switch:

- Remove front panel.
- Disconnect wire from switch at rear.
- Press and push switch from rear of the panel
- Replace in reverse order.

## Trouble Shooting

<u>Problem</u>	<u>Solution</u>
Burner will not light	<ul style="list-style-type: none"><li>- Check gas supply to burner by manually lighting the burners.</li><li>- See electrode for visible damage, replace if damaged.</li></ul>
Improper burner flame	<ul style="list-style-type: none"><li>- Check burner gas inlet area for any blockage and clear.</li><li>- Check orifice hoods for any clogging and clean.</li><li>- Adjust air shutter, if necessary.</li><li>- Check pressure if flame is too low or too high.</li><li>- Check gas supply tank (LP) if running low.</li></ul>
Light is not ON	<ul style="list-style-type: none"><li>- Connect 115V power at rear. Turn switch ON.</li><li>- Check bulb. Replace if necessary.</li></ul>

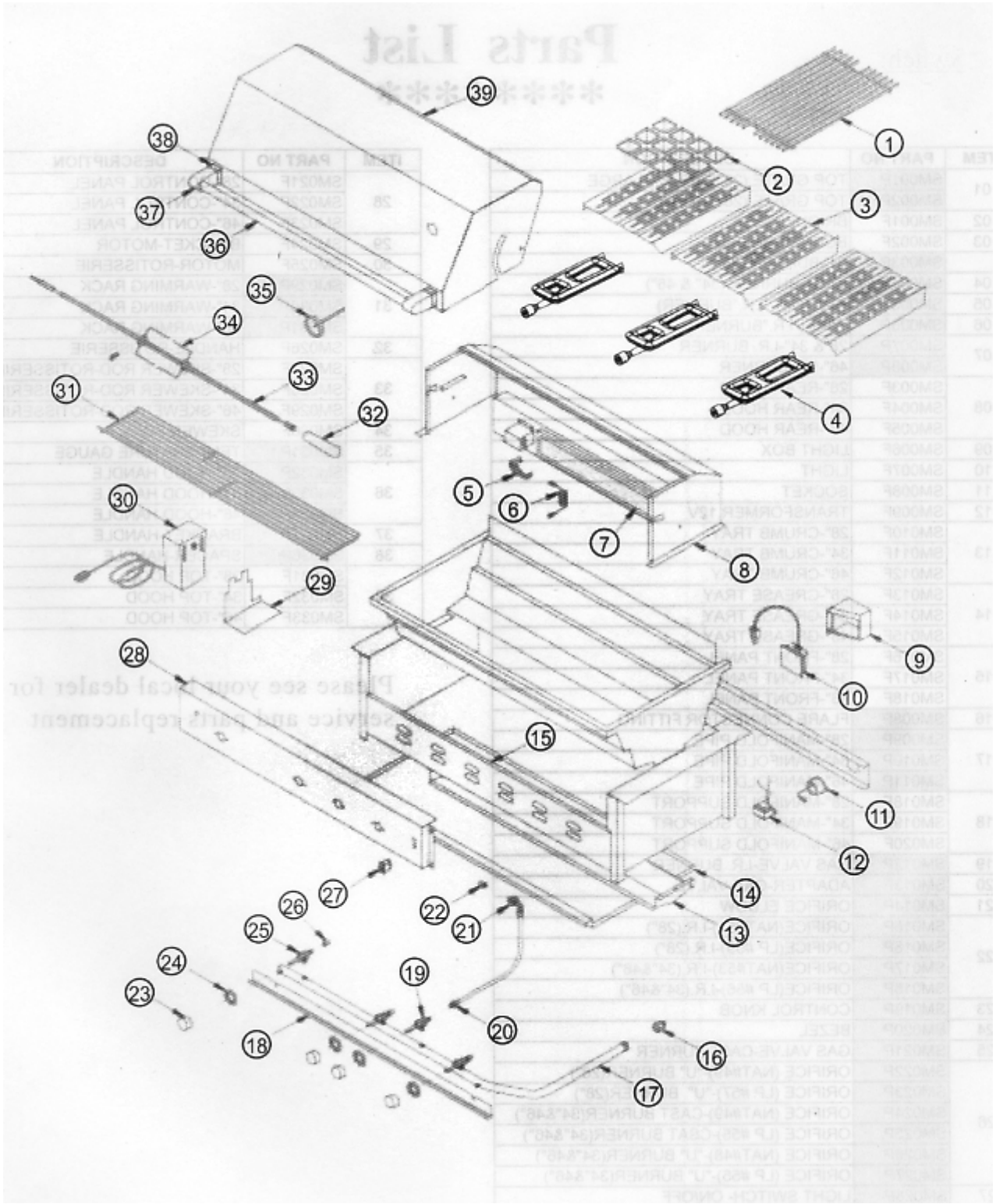

# Parts List

\*\*\*\*\*

ITEM	PART NO	DESCRIPTION
01	SM001P	TOP GRATE (28",34"&46")-LARGE
	SM002P	TOP GRATE (28")-SMALL
02	SM001F	BRIQUETTES
03	SM002F	BURNER SHIELD
	SM003P	"U" BURNER (28")
04	SM004P	CAST BURNER (34" & 46")
05	SM005P	IGNITOR ("I.R." BURNER)
06	SM006P	WIRE ("I.R." BURNER)
07	SM007P	28" & 34"-I.R. BURNER
	SM008P	46"-I.R. BURNER
08	SM003F	28"-REAR HOOD
	SM004F	34"-REAR HOOD
	SM005F	46" -REAR HOOD
09	SM006F	LIGHT BOX
10	SM007F	LIGHT
11	SM008F	SOCKET
12	SM009F	TRANSFORMER 12V
13	SM010F	28"-CRUMB TRAY
	SM011F	34" -CRUMB TRAY
	SM012F	46" -CRUMB TRAY
14	SM013F	28"-GREASE TRAY
	SM014F	34" -GREASE TRAY
	SM015F	46" -GREASE TRAY
15	SM016F	28"-FRONT PANEL
	SM017F	34" -FRONT PANEL
	SM018F	46" -FRONT PANEL
16	SM008P	FLARE CONNECTOR FITTING
17	SM009P	28"-MANIFOLD PIPE
	SM010P	34" -MANIFOLD PIPE
	SM011P	46" -MANIFOLD PIPE
18	SM018F	28"-MANIFOLD SUPPORT
	SM019F	34" -MANIFOLD SUPPORT
	SM019F	46" -MANIFOLD SUPPORT
19	SM012P	GAS VALVE-I.R. BURNER
20	SM013P	ADAPTER-GAS VALVE
21	SM014P	ORIFICE ELBOW
22	SM015P	ORIFICE (NAT#51)-I.R. (28")
	SM016P	ORIFICE (LP #59)-I.R. (28")
	SM017P	ORIFICE (NAT#53)-I.R. (34"&46")
	SM018P	ORIFICE (LP #56)-I.R. (34"&46")
23	SM019P	CONTROL KNOB
24	SM020P	EVZEL
25	SN021P	GAS VALVE-CAST BURNER
26	SM022P	ORIFICE (NAT#49)-"U" BURNER(28")
	SM023P	ORIFICE (LP #57)-"U" BURNER(28")
	SM024P	ORIFICE (NAT#49)-"U" BURNER(34"&46")
	SM025P	ORIFICE (LP #55)-"U" BURNER(34"&46")
	SM026P	ORIFICE (NAT#48)-"U" BURNER(34"&46")
	SM027P	ORIFICE (LP #55)-"U" BURNER(34"&46")
27	SM028P	LIGHT SWITCH - ON/OFF

ITEM	PART NO	DESCRIPTION
28	SM021F	28"-CONTROL PANEL
	SM022F	34"-CONTROL PANEL
	SM023F	46"-CONTROL PANEL
29	SM024F	BRACKET-MOTOR
30	SM025F	MOTOR-ROTISSERIE
31	SM029P	28"-WARMING RACK
	SM030P	34"-WARMING RACK
	SM031P	46"-WARMING RACK
32	SM026F	HANDLE-ROTISSERIE
33	SM027F	28"-SKEWER ROD-ROTISSERIE
	SM028F	34"-SKEWER ROD-ROTISSERIE
	SM029F	46"-SKEWER ROD-ROTISSERIE
34	SM030F	SKEWER FORK
35	SM031P	TEMPERATURE GAUGE
36	SM032P	28"-HOOD HANDLE
	SM033P	34"-HOOD HANDLE
	SM034P	46"-HOOD HANDLE
37	SM035P	BRACKET-HANDLE
38	SM036P	SPACER-HANDLE
39	SM031F	28"-TOP HOOD
	SM032F	34"-TOP HOOD
	SM033F	46"-TOP HOOD
40	SM037P	27"-HANDLE
	SM038P	36"-HANDLE
41	SM039P	BRACKET - HANDLE
42	SM040P	SPACER - HANDLE
43	SM218F	27"-TOP HOOD
	SM219F	36"-TOP HOOD

Please see your local dealer for service and parts replacement: